

THIS DOCUMENT CONTAINS INFORMATION PROPRIETARY TO DELTA MICROWAVE. ANY REPRODUCTION WITHOUT WRITTEN PERMISSION IS EXPRESSLY PROHIBITED.

CUST. APPROVAL	ZONE	REV	DESCRIPTION	DATE	APPROVED
		-	PRELIMINARY	09/21/12	W.K.
		A	RELEASED TO PRODUCTION	12/27/12	W.K.
		B	ECO#110242	10/07/14	

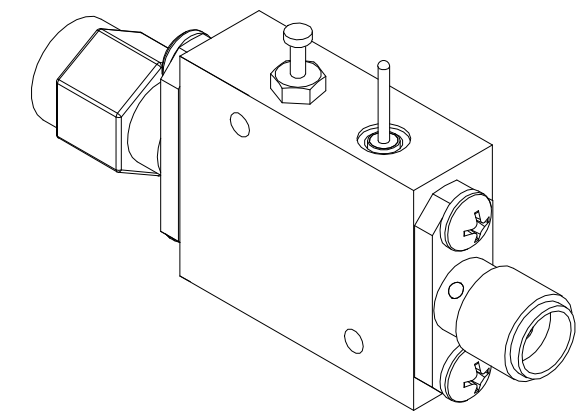
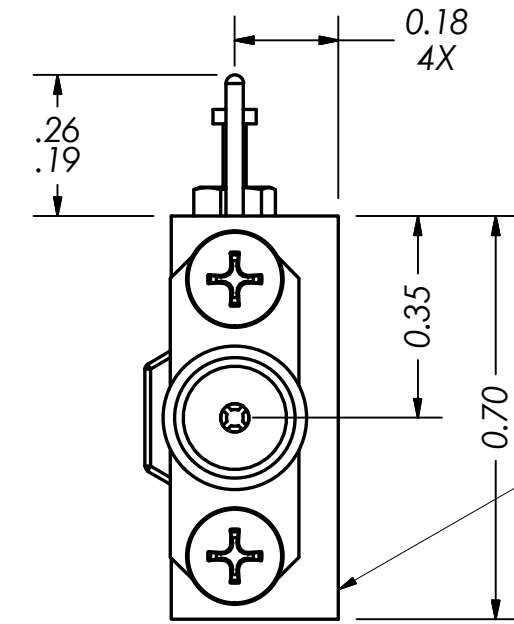
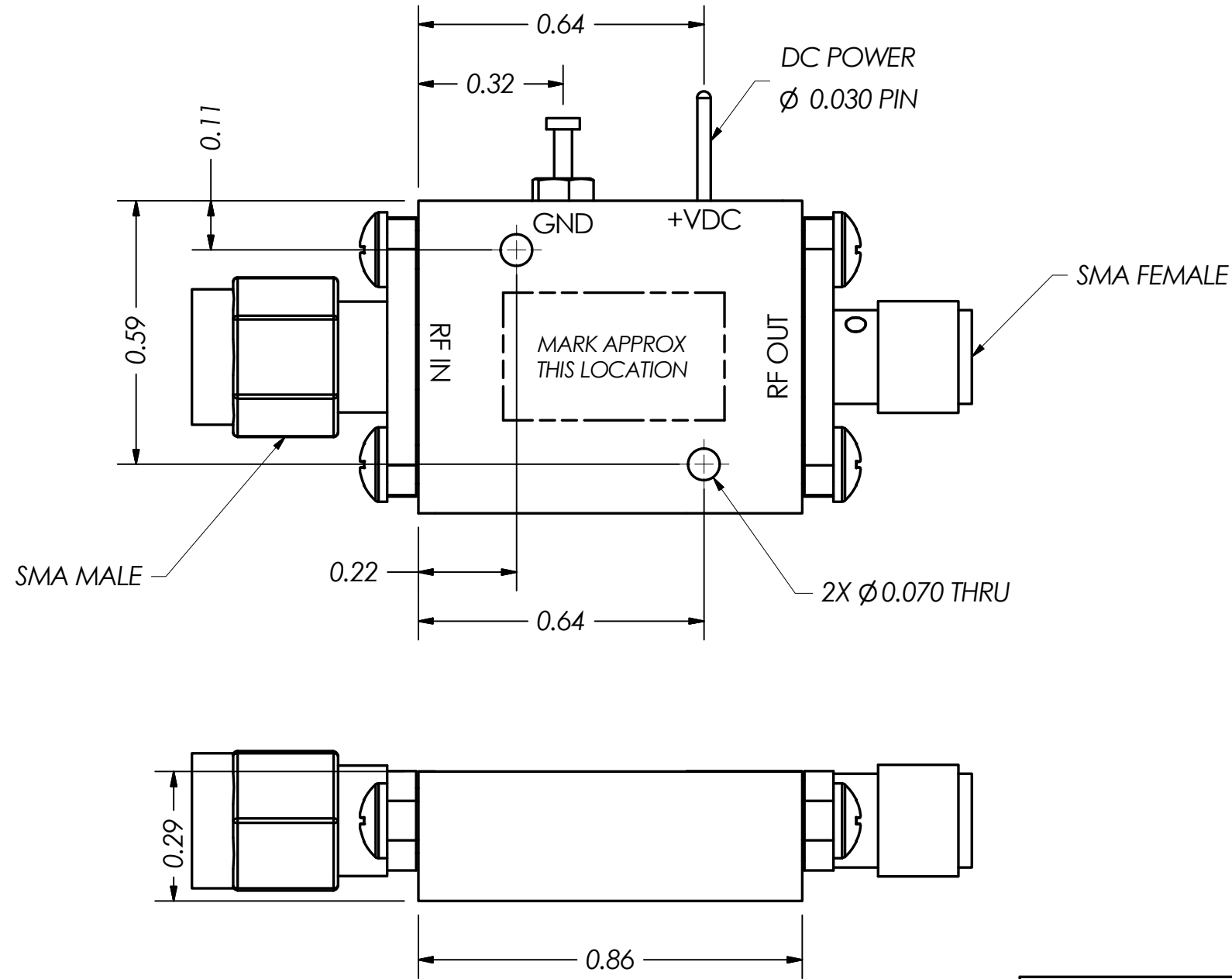

2. MARKING: USING LABEL OR BLACK EPOXY INK TO INCLUDE:
DELTA MICROWAVE, MODEL NO., SERIAL NO.,
CODE IDENT. NO. 51719 AND DATE CODE

1: FINISH: HAZE GRAY EPOXY POLYAMIDE TOPCOAT
PER MIL-DTL-24441C, SUP.1
MIL-DTL-24441/21, TYP 3, FORMULA 151
USING GREEN EPOXY POLYAMIDE PRIMER
MIL-DTL-24441/20, TYP 3, FORMULA 150

NOTES:

UNLESS OTHERWISE SPECIFIED DIMENSIONS ARE IN INCHES TOLERANCES ARE: FRACTIONS DECIMALS ANGLES + .xx ± .01 ± 1° - .xxx ± .005 -		CONTRACT NO. <i>DM-LNC-25-101</i>	
APPROVALS		DATE	
DRAWN D.F.ESTABROOK		09/21/12	
REVISD D.F.ESTABROOK		10/07/14	
CHECKED			
APPROVED			
MATERIAL		FINISH	
USED ON MODEL#		DO NOT SCALE DRAWING	
		INTERPRET DRAWINGS PER ASME Y14.100 and ASME Y14.24	

 Delta Microwave Inc. 300 Del Norte Boulevard Oxnard CA. 93030		
TITLE		
OUTLINE		
SIZE	CODE IDENT NO.	DWG NO
B	51719	001-0010
SCALE 3:1	SHEET 1 OF 1	