

THIS DOCUMENT CONTAINS INFORMATION PROPRIETARY TO DELTA MICROWAVE. ANY REPRODUCTION OF THIS DOCUMENT WITHOUT WRITTEN PERMISSION IS EXPRESSLY PROHIBITED.

REVISIONS				
ZONE	REV	DESCRIPTION	DATE	APPROVED
	A	RELEASED	11/23/99	<i>[Signature]</i>

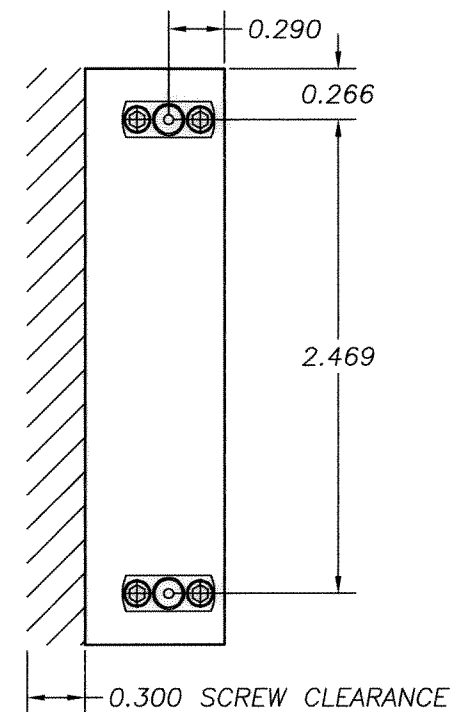
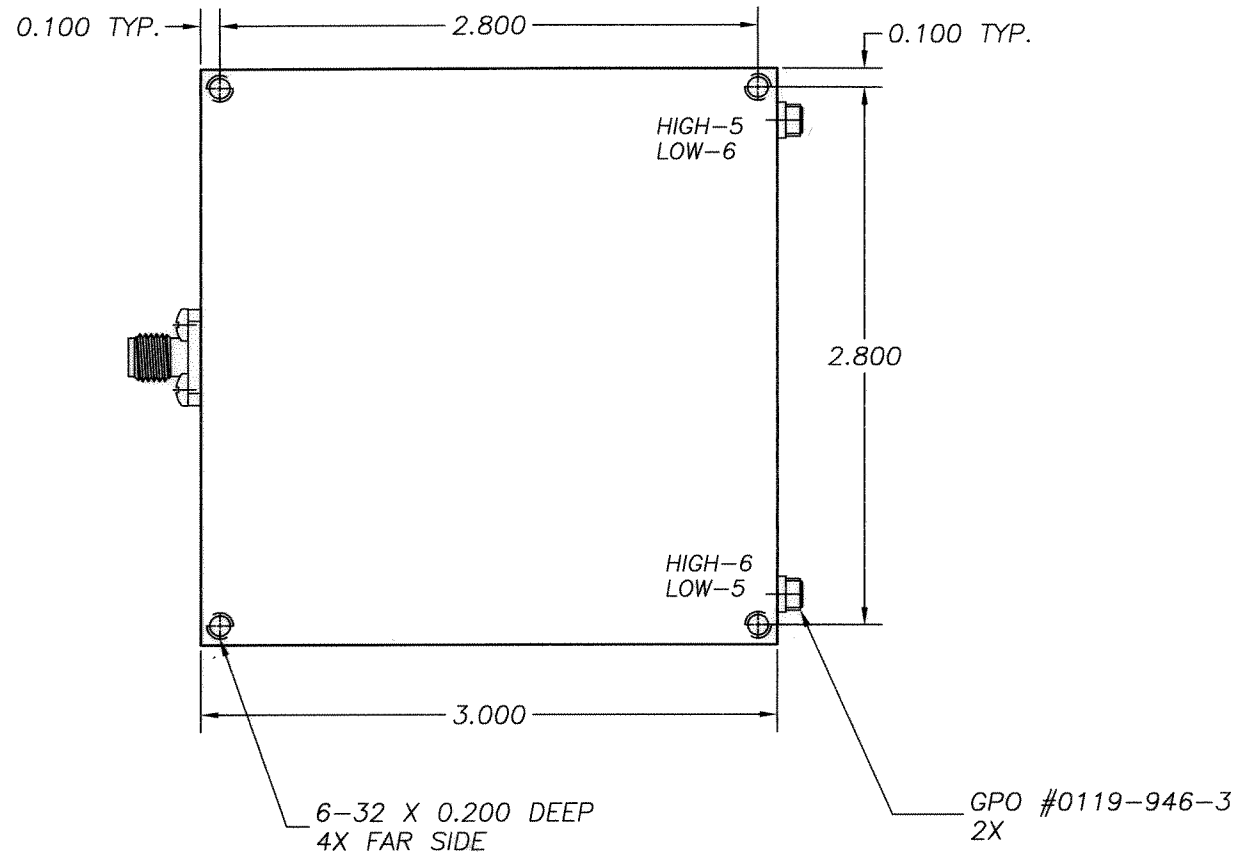
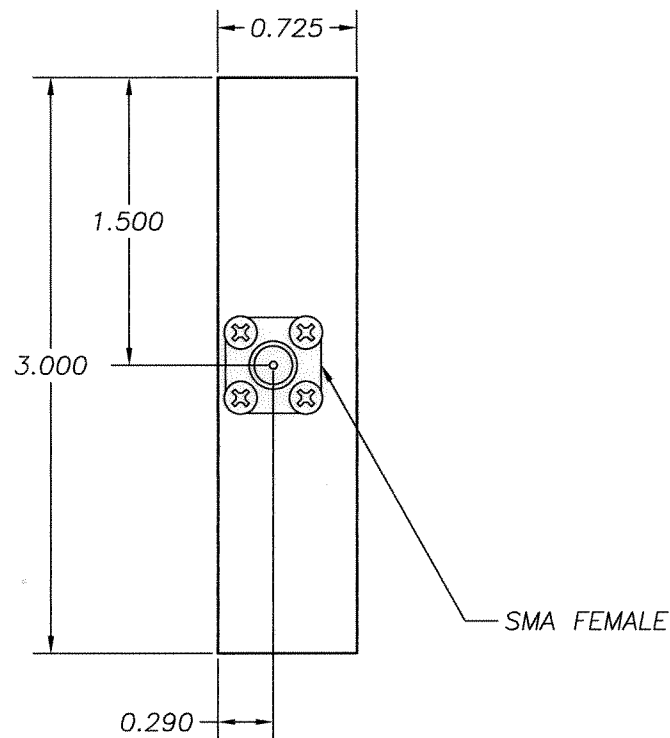

2. MARKING: USING BLACK WARNOW INK TO INCLUDE:  
DELTA MICROWAVE, MODEL NO., SERIAL NO.,  
CODE IDENT. NO. 51719 AND DATE CODE

1: FINISH: HAZE GRAY EPOXY POLYAMIDE TOPCOAT  
PER MIL-P-24441B TYP.1  
(AS)COLOR NO.26270, FORMULA 151  
PER MIL-P-24441/1C, QPL 24441-103  
USING EPOXY POLYAMIDE PRIMER  
PER MIL-P-24441B TYP.1 24272 GREEN  
FORMULA 150 PER MIL-P-24441/1C, QPL 24441-103

NOTES:

QTY REQD	CODE IDENT	PART OR IDENTIFYING NO.	NOMENCLATURE OR DESCRIPTION	MATERIAL SPECIFICATION
PARTS LIST				
UNLESS OTHERWISE SPECIFIED DIMENSIONS ARE IN INCHES TOLERANCES ARE: FRACTIONS DECIMALS ANGLES + .XX ± .03 ± - .XXX ± .010 -		CONTRACT NO. C5515	<b>DELTA microwave</b> DELTA MICROWAVE 1301 VANGUARD DR. OXNARD CALIFORNIA 93033	
MATERIAL		APPROVALS DRAWN D.R. BOWLER	DATE 11/23/99	TITLE OUTLINE
FINISH		CHECKED	APPROVED <i>[Signature]</i>	SIZE B
DO NOT SCALE DRAWING		CODE IDENT NO. 51719		DRAWING NO. C5515
SCALE FULL			SHEET 1 OF 1	