

THIS DOCUMENT CONTAINS INFORMATION PROPRIETARY TO DELTA MICROWAVE. ANY REPRODUCTION OF THIS DOCUMENT WITHOUT WRITTEN PERMISSION IS EXPRESSLY PROHIBITED.

| REVISIONS | | | | |
|-----------|-----|-------------|----------|--------------------|
| ZONE | REV | DESCRIPTION | DATE | APPROVED |
| | A | RELEASED | 06/29/01 | <i>[Signature]</i> |

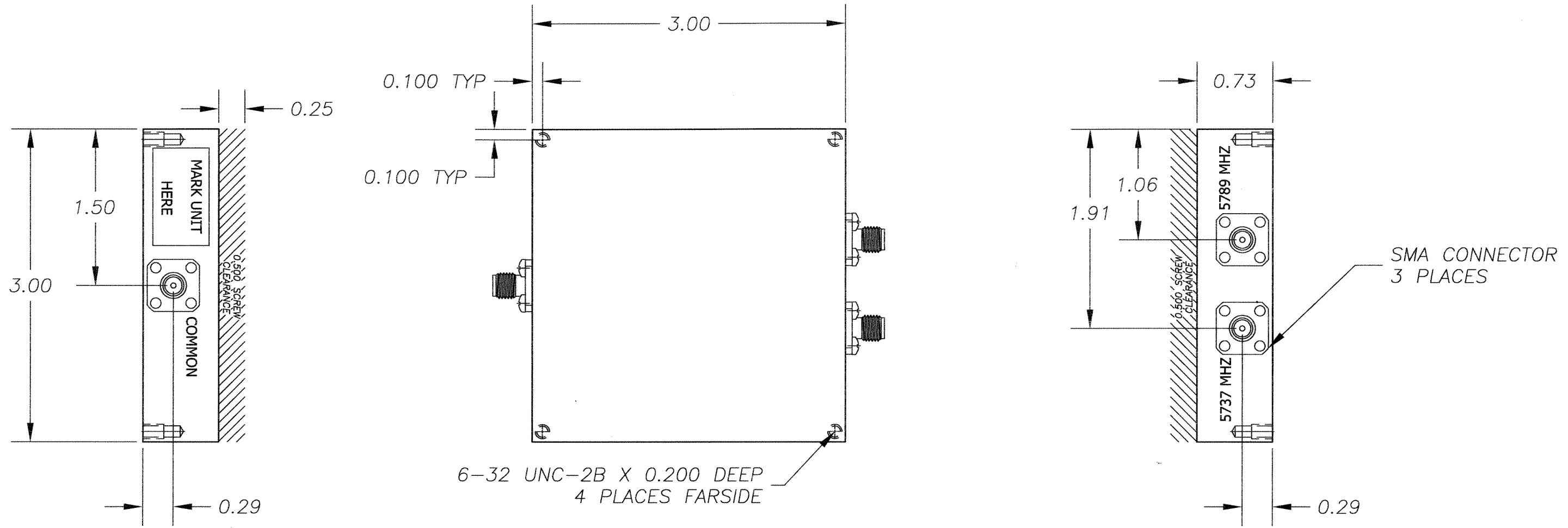

2. MARKING: USING BLACK WARNOW INK TO INCLUDE:
 DELTA MICROWAVE, MODEL NO., SERIAL NO.,
 CODE IDENT. NO. 51719 AND DATE CODE

1: FINISH: HAZE GRAY EPOXY POLYAMIDE TOPCOAT
 PER MIL-P-24441B TYP.1
 (AS)COLOR NO.26270, FORMULA 151
 PER MIL-P-24441/1C, QPL 24441-103
 USING EPOXY POLYAMIDE PRIMER
 PER MIL-P-24441B TYP.1 24272 GREEN
 FORMULA 150 PER MIL-P-24441/1C, QPL 24441-103

NOTES:

| QTY REQD | CODE IDENT | PART OR IDENTIFYING NO. | NOMENCLATURE OR DESCRIPTION | MATERIAL SPECIFICATION |
|---|------------|--------------------------------|--|------------------------|
| PARTS LIST | | | | |
| UNLESS OTHERWISE SPECIFIED DIMENSIONS ARE IN INCHES TOLERANCES ARE: FRACTIONS DECIMALS ANGLES + .XX ±.03 + - .XXX ±.010 - | | CONTRACT NO. C5516 | DELTA microwave 1301 VANGUARD DR. OXNARD CALIFORNIA 93033 | |
| MATERIAL | | APPROVALS | DATE | TITLE |
| FINISH | | DRAWN N. CASTRO | 06/29/01 | OUTLINE |
| C5516 | | CHECKED <i>[Signature]</i> | 07/30/01 | |
| USED ON MODEL# | | APPROVED <i>[Signature]</i> | 8-30-01 | SIZE B |
| DO NOT SCALE DRAWING | | CODE IDENT NO. 51719 | | DRAWING NO. C5516-1 |
| | | | SCALE 2/1 | SHEET 1 OF 1 |