

THIS DOCUMENT CONTAINS INFORMATION PROPRIETARY TO DELTA MICROWAVE. ANY REPRODUCTION OF THIS DOCUMENT WITHOUT WRIT- TEN PERMISSION IS EXPRESSLY PROHIBITED.

REVISIONS				
ZONE	REV	DESCRIPTION	DATE	APPROVED
	A	RELEASED	01/29/01	<i>[Signature]</i>

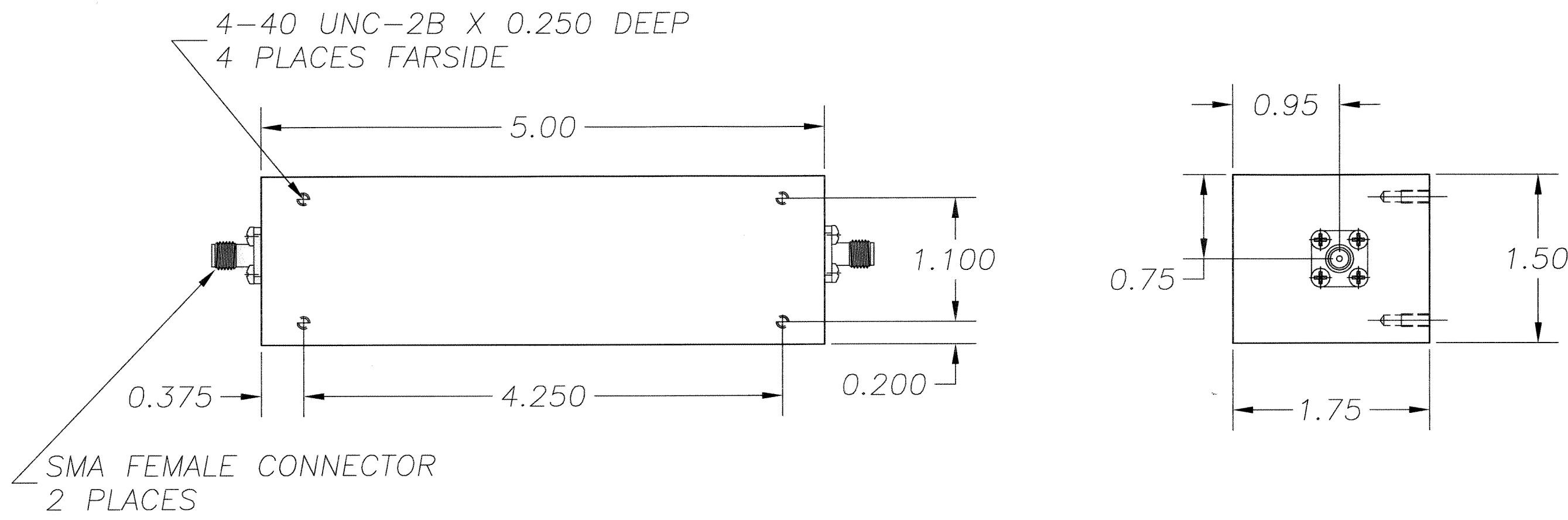

2. MARKING: USING BLACK WARNOW INK TO INCLUDE:
DELTA MICROWAVE, MODEL NO., SERIAL NO.,
CODE IDENT. NO. 51719 AND DATE CODE

1: FINISH: HAZE GRAY EPOXY POLYAMIDE TOPCOAT
PER MIL-P-24441B TYP.1
(AS)COLOR NO.26270, FORMULA 151
PER MIL-P-24441/1C, QPL 24441-103
USING EPOXY POLYAMIDE PRIMER
PER MIL-P-24441B TYP.1 24272 GREEN
FORMULA 150 PER MIL-P-24441/1C, QPL 24441-103

NOTES:

QTY REQD	CODE IDENT	PART OR IDENTIFYING NO.	NOMENCLATURE OR DESCRIPTION	MATERIAL SPECIFICATION
PARTS LIST				
UNLESS OTHERWISE SPECIFIED DIMENSIONS ARE IN INCHES		CONTRACT NO. L1479		DELTA microwave 1301 VANGUARD DR. OXNARD CALIFORNIA 93033
TOLERANCES ARE: FRACTIONS DECIMALS ANGLES + .xx ±.01 ± - .xxx ±.005 -		APPROVALS	DATE	
MATERIAL		DRAWN	DATE	TITLE OUTLINE
ALUMINUM ALLOY 6061-T6 QQ-A-250/11		CHECKED <i>[Signature]</i>	1/30/01	
FINISH SILVER PLATE .0003-.0005 THK QQ-S-365, TY.2, GR.B		APPROVED <i>[Signature]</i>	1-30-01	SIZE
L1479				B
USED ON MODEL#	DO NOT SCALE DRAWING			CODE IDENT NO. 51719
				DRAWING NO. L1479
				SCALE FULL
				SHEET 1 OF 1