

THIS DOCUMENT CONTAINS INFORMATION PROPRIETARY TO DELTA MICROWAVE. ANY REPRODUCTION OF THIS DOCUMENT WITHOUT WRITTEN PERMISSION IS EXPRESSLY PROHIBITED.

| REVISIONS | | | | |
|-----------|-----|-------------|---------|----------|
| ZONE | LTR | DESCRIPTION | DATE | APPROVED |
| | A | RELEASED | 5-10-85 | |

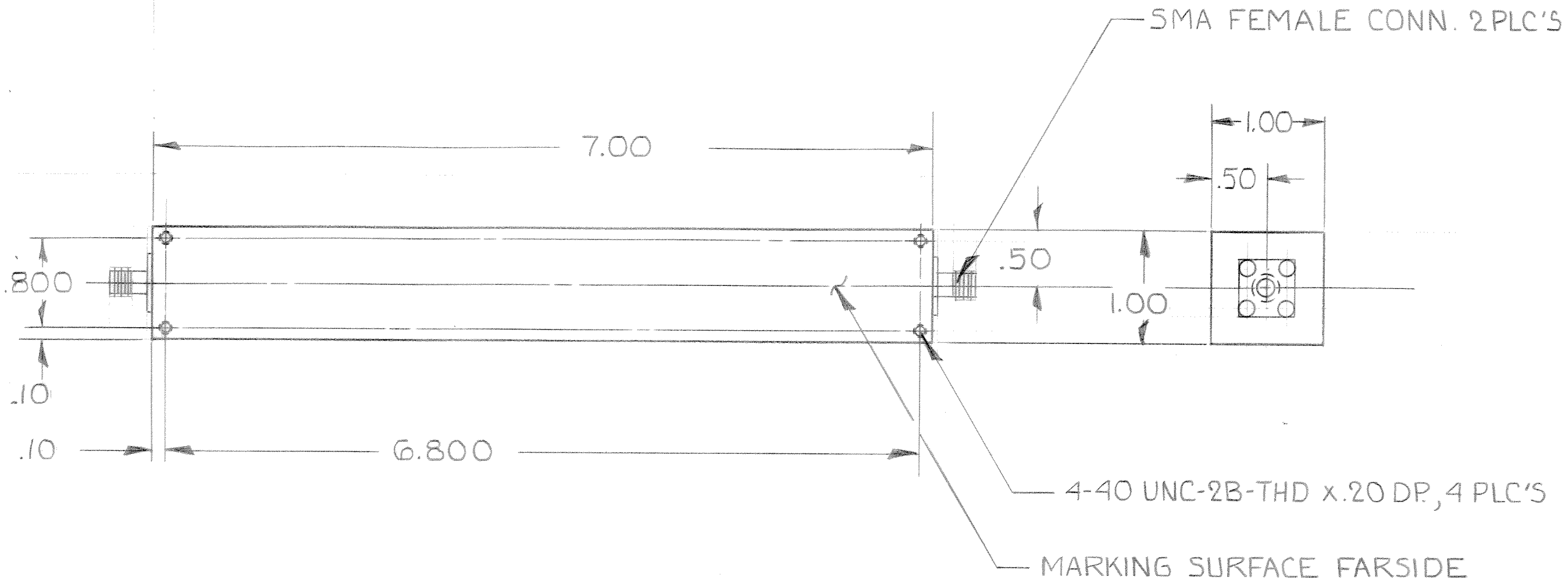

2. MARKING: USING BLACK WORNOW INK, TO INCLUDE DELTA MICROWAVE, MODEL NO. L1612 SERIAL NO., CODE INDET NO. 51719 AND DATE CODE
1. FINISH: GREY POLYURETHANE COATING PER MIL-C-81773 (AS) COLOR NO. 16440, PER FED STD 595 USING EPOXY PRIMER MIL-P-23377C

NOTES:

| QTY REQD | CODE IDENT | PART OR IDENTIFYING NO. | NOMENCLATURE OR DESCRIPTION | MATERIAL SPECIFICATION |
|--|------------|-------------------------|---|------------------------|
| PARTS LIST | | | | |
| UNLESS OTHERWISE SPECIFIED DIMENSIONS ARE IN INCHES TOLERANCES ARE: FRACTIONS DECIMALS ANGLES ± N/A .XX ±.03 ± N/A .XXX ±.010 | | | DELTA MICROWAVE 840 VIA ALONDRA CAMARILLO, CALIFORNIA 93010 | |
| CONTRACT NO. | | | BANDPASS FILTER OUTLINE | |
| APPROVALS | | DATE | | |
| DRAWN <i>J. Alvey</i> | | 5-10-85 | | |
| CHECKED <i>Danf...</i> | | 5-10-85 | | |
| MATERIAL | | | SIZE | CODE IDENT NO. |
| FINISH | | | B | 51719 |
| DO NOT SCALE DRAWING | | | DRAWING NO. | L1612 |
| | | | SCALE FULL | SHEET OF |