

THIS DOCUMENT CONTAINS INFORMATION PROPRIETARY TO DELTA MICROWAVE. ANY REPRODUCTION OF THIS DOCUMENT WITHOUT WRIT- TEN PERMISSION IS EXPRESSLY PROHIBITED.

REVISIONS				
ZONE	REV	DESCRIPTION	DATE	APPROVED
	A	RELEASED	04/07/99	R.E.S.
	B	REDRAWN TO REV.B HOUSING DIMENSIONS	05/27/99	R.E.S.
	C	ECO#105054 ADDED CUSTOMER P.N.	09/13/00	R.E.S.
	D	ECO#105110 CHANGE L1 TO L-BAND	11/09/00	<i>[Signature]</i>

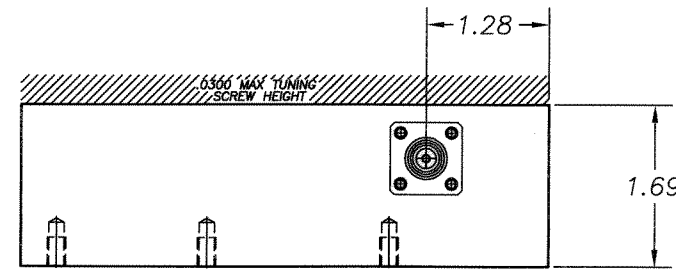
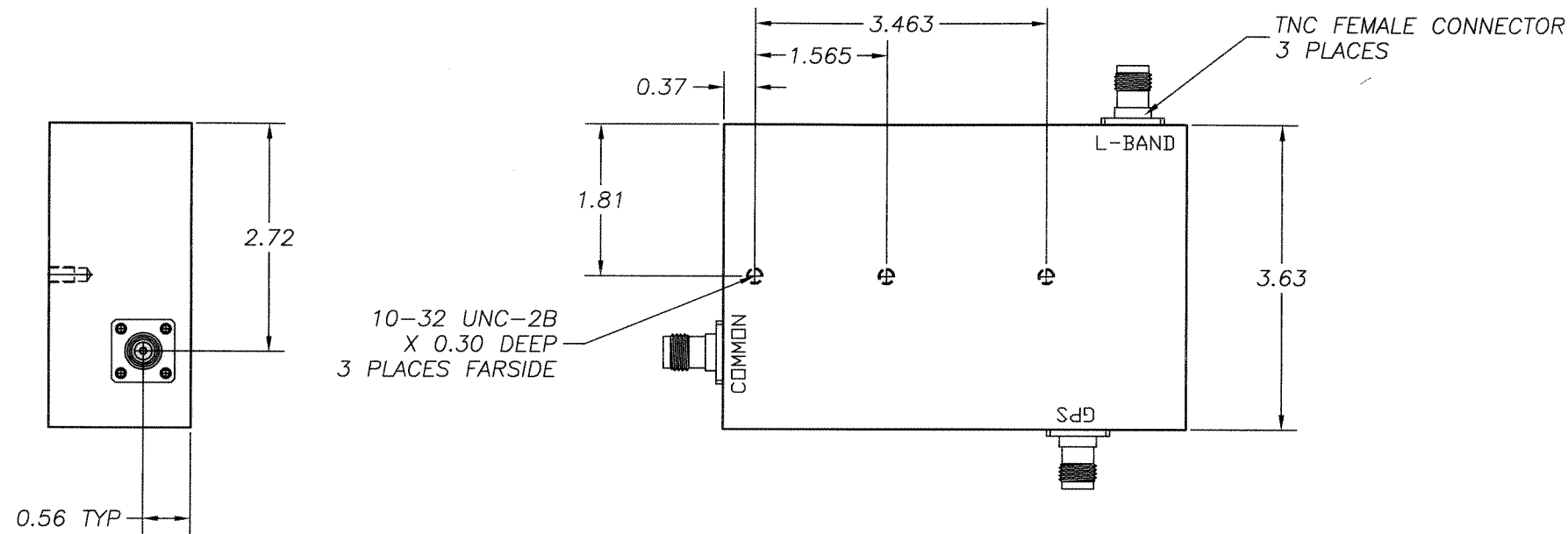
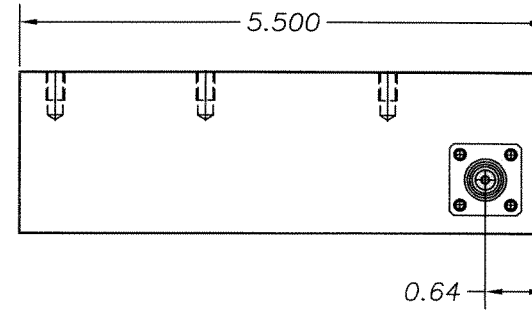

2. MARKING: USING BLACK WARNOW INK TO INCLUDE: DELTA MICROWAVE, MODEL NO., SERIAL NO., CODE IDENT. NO. 51719 AND DATE CODE AND TRIMBLE PART NUMBER TNL43580

1: FINISH: HAZE GRAY EPOXY POLYAMIDE TOPCOAT PER MIL-P-24441B TYP.1 (AS)COLOR NO.26270, FORMULA 151 PER MIL-P-24441/1C, QPL 24441-103 USING EPOXY POLYAMIDE PRIMER PER MIL-P-24441B TYP.1 24272 GREEN FORMULA 150 PER MIL-P-24441/1C, QPL 24441-103

NOTES:

QTY REQD	CODE IDENT	PART OR IDENTIFYING NO.	NOMENCLATURE OR DESCRIPTION	MATERIAL SPECIFICATION
PARTS LIST				
UNLESS OTHERWISE SPECIFIED DIMENSIONS ARE IN INCHES TOLERANCES ARE: FRACTIONS DECIMALS ANGLES		CONTRACT NO. L5349		<b>DELTA microwave</b> <b>DELTA MICROWAVE</b> 1301 VANGUARD DR. OXNARD CALIFORNIA 93033
+	-	.xx ±.01 .xxx ±.005	APPROVALS DATE	
MATERIAL		DRAWN D.F. ESTABROOK	04/07/99	TITLE
FINISH		CHECKED <i>[Signature]</i>	11/9/00	OUTLINE
L5349		APPROVED <i>[Signature]</i>	11-9-00	SIZE B
USED ON MODEL#		DO NOT SCALE DRAWING		CODE IDENT NO. 51719
				DRAWING NO. L5349
				SCALE 1/2
				SHEET 1 OF 1