

THIS DOCUMENT CONTAINS INFORMATION PROPRIETARY TO DELTA MICROWAVE. ANY REPRODUCTION OF THIS DOCUMENT WITHOUT WRIT- TEN PERMISSION IS EXPRESSLY PROHIBITED.

REVISIONS				
ZONE	REV	DESCRIPTION	DATE	APPROVED
	A	RELEASED	01/17/00	

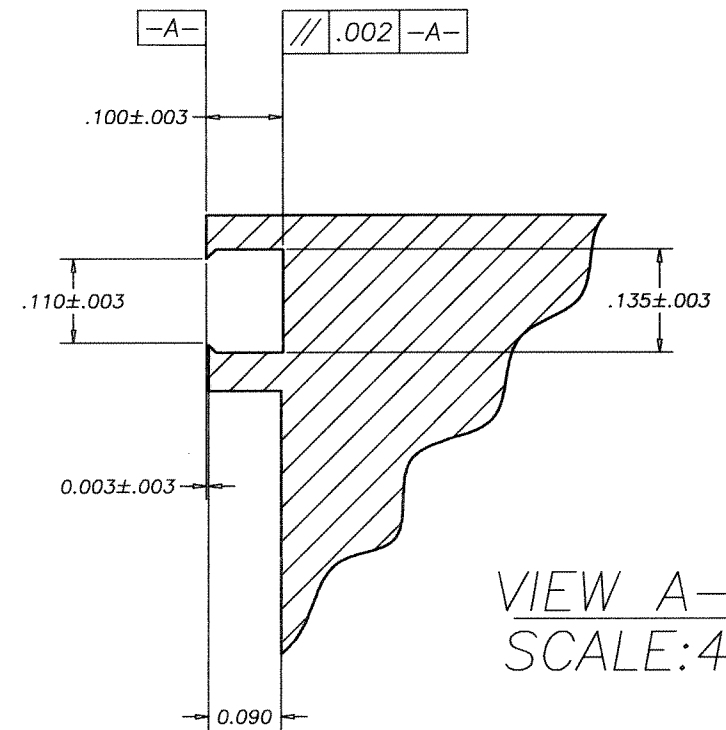
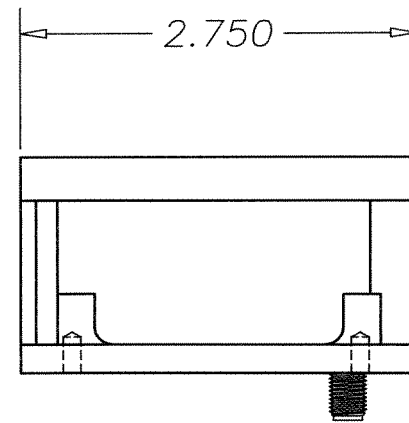
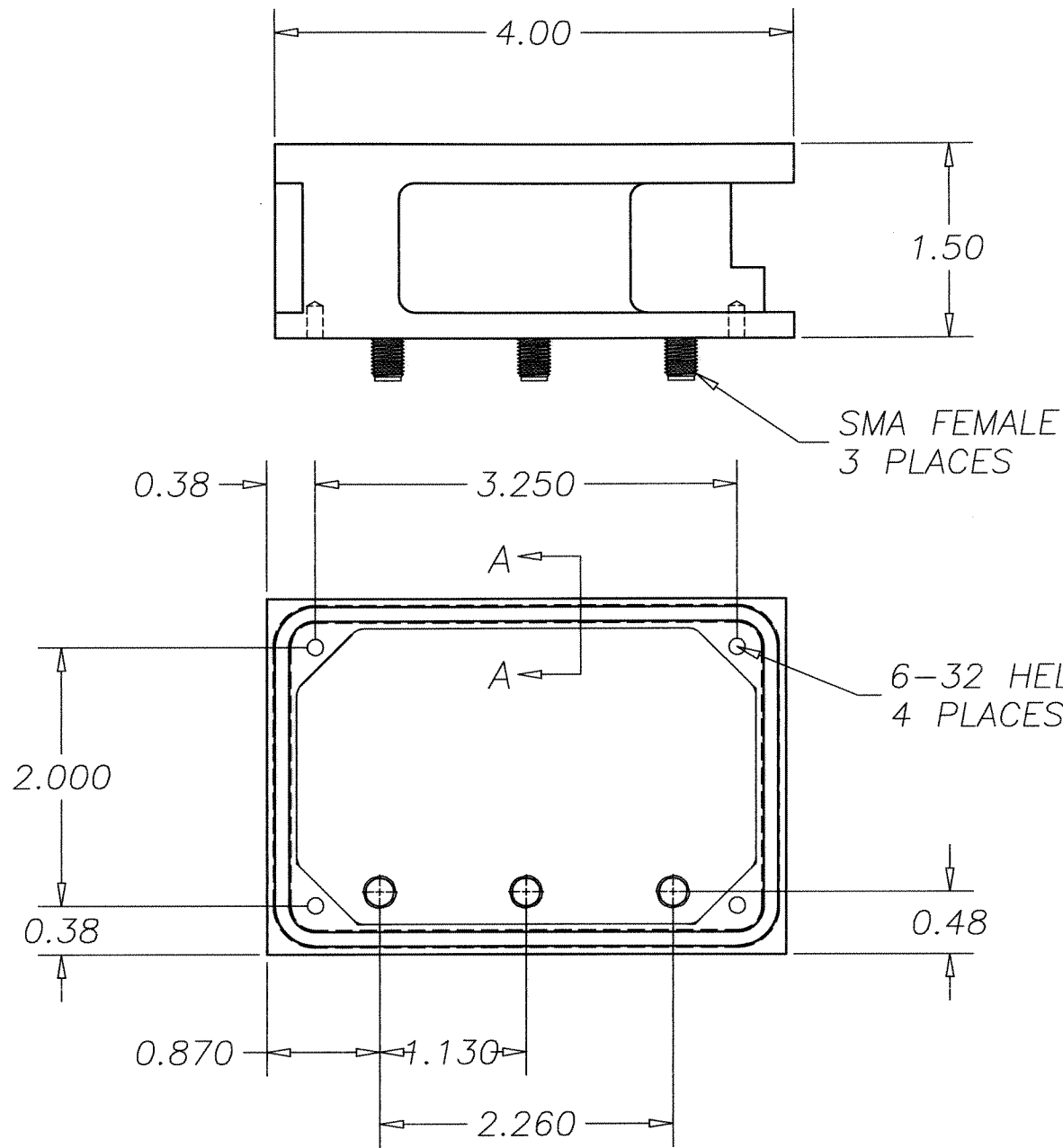

VIEW A-A  
SCALE: 4X

2. MARKING: USING BLACK WARNOW INK TO INCLUDE: DELTA MICROWAVE, MODEL NO., SERIAL NO., CODE IDENT. NO. 51719 AND DATE CODE

1: FINISH: HAZE GRAY EPOXY POLYAMIDE TOPCOAT PER MIL-P-24441B TYP.1 (AS) COLOR NO.26270, FORMULA 151 PER MIL-P-24441/1C, QPL 24441-103 USING EPOXY POLYAMIDE PRIMER PER MIL-P-24441B TYP.1 24272 GREEN FORMULA 150 PER MIL-P-24441/1C, QPL 24441-103

NOTES:

QTY REQD	CODE IDENT	PART OR IDENTIFYING NO.	NOMENCLATURE OR DESCRIPTION	MATERIAL SPECIFICATION
PARTS LIST				
UNLESS OTHERWISE SPECIFIED DIMENSIONS ARE IN INCHES		CONTRACT NO. L5634		DELTA MICROWAVE 1301 VANGUARD DR. OXNARD CALIFORNIA 93033
TOLERANCES ARE: FRACTIONS DECIMALS ANGLES + .xx ± .01 + - .xxx ± .005 -		APPROVALS	DATE	
MATERIAL		DRAWN D.F. ESTABROOK	01/17/00	TITLE <b>OUTLINE</b>
FINISH		CHECKED		SIZE B
L5634		APPROVED	1/20/00	CODE IDENT NO. 51719
USED ON MODEL#		DO NOT SCALE DRAWING		DRAWING NO. L5634
			SCALE 3/4	SHEET 1 OF 1