

4

3

2

1

THIS DOCUMENT CONTAINS INFORMATION PROPRIETARY TO DELTA MICROWAVE. ANY REPRODUCTION OF THIS DOCUMENT WITHOUT WRITTEN PERMISSION IS EXPRESSLY PROHIBITED.

REVISIONS				
ZONE	REV	DESCRIPTION	DATE	APPROVED
	A	RELEASED	02/17/98	<i>[Signature]</i>

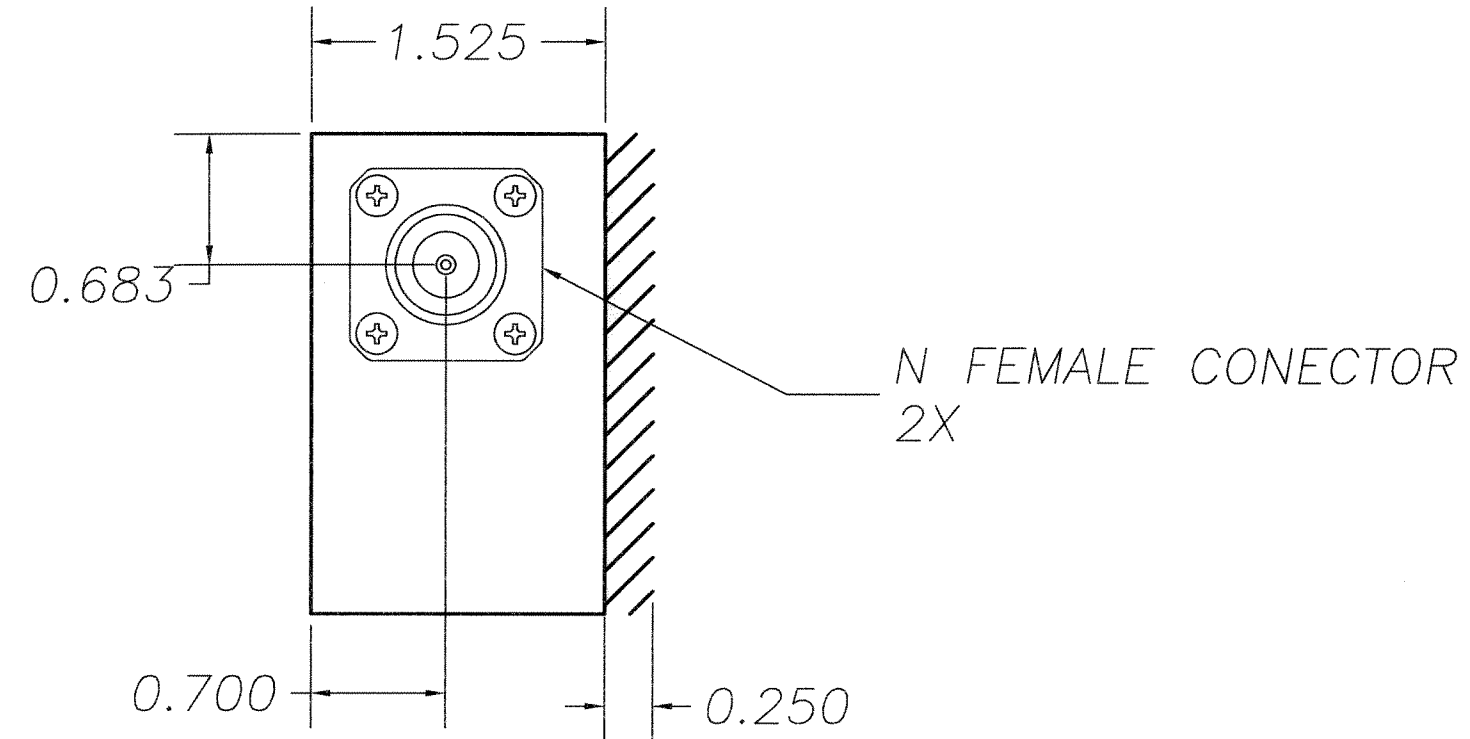
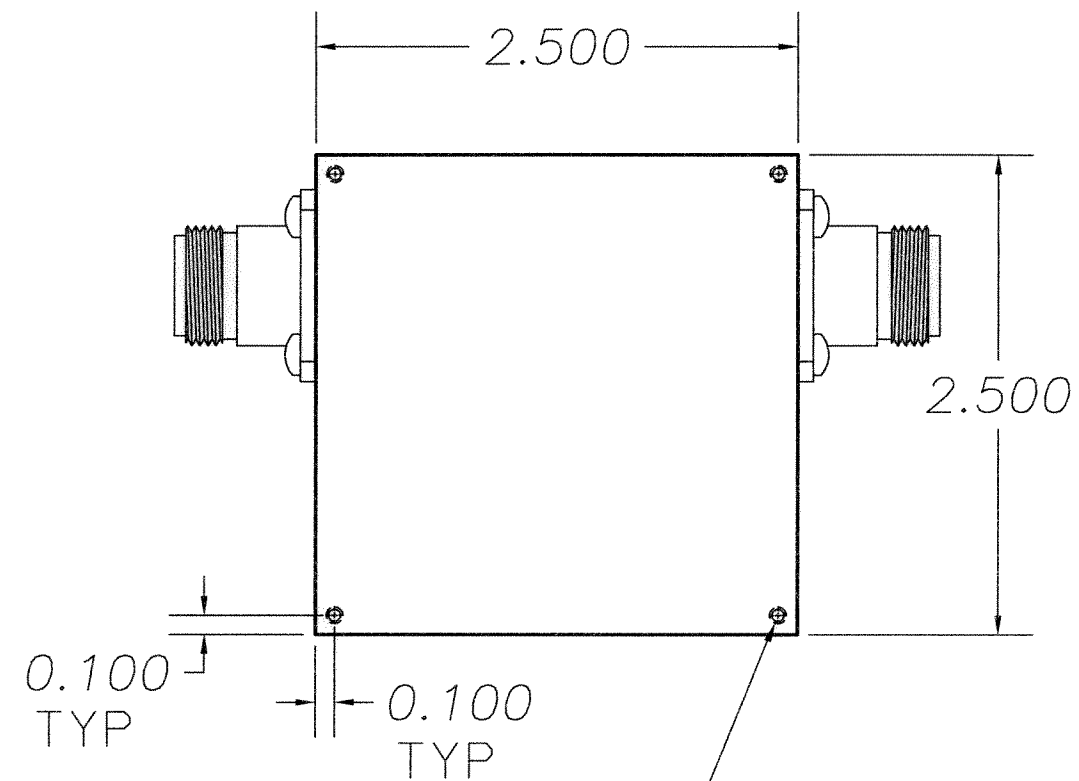

2-56 UNC-2B X 0.150 DEEP 4X

1. MARKING: USING BLACK WARNOW INK TO INCLUDE: DELTA MICROWAVE, MODEL NO., SERIAL NO., CODE IDENT. NO. 51719 AND DATE CODE

NOTES:

QTY REQD	CODE IDENT	PART OR IDENTIFYING NO.	NOMENCLATURE OR DESCRIPTION	MATERIAL SPECIFICATION
PARTS LIST				
UNLESS OTHERWISE SPECIFIED DIMENSIONS ARE IN INCHES TOLERANCES ARE: FRACTIONS DECIMALS ANGLES + .XX ± .03 ± - .XXX ± .010 ±		CONTRACT NO. S1455	DELTA microwave 1301 VANGUARD DR. OXNARD CALIFORNIA 93033	
MATERIAL		APPROVALS DRAWN D.R.BOWLER	DATE 02/17/98	TITLE OUTLINE
FINISH		CHECKED <i>[Signature]</i>	DATE 2/17/98	SIZE B
DO NOT SCALE DRAWING		APPROVED <i>[Signature]</i>	DATE 2/17/98	CODE IDENT NO. 51719
			DRAWING NO. S1455	SHEET 1 OF 1

4

3

2

1