

THIS DOCUMENT CONTAINS INFORMATION PROPRIETARY TO DELTA MICROWAVE. ANY REPRODUCTION WITHOUT WRITTEN PERMISSION IS EXPRESSLY PROHIBITED.

ZONE	REV	DESCRIPTION	DATE	APPROVED
	A	PRELIMINARY RELEASE	01/05/06	

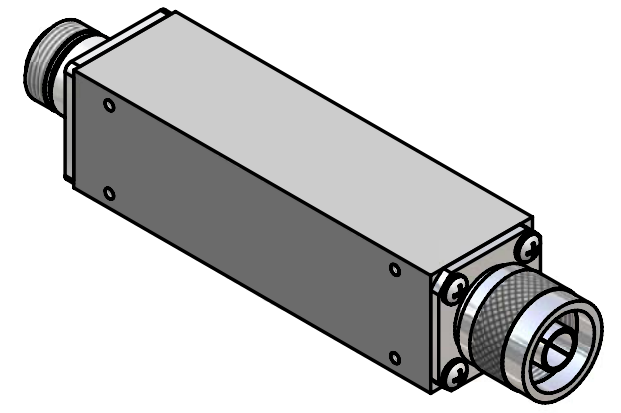

TYPE "N" FEMALE

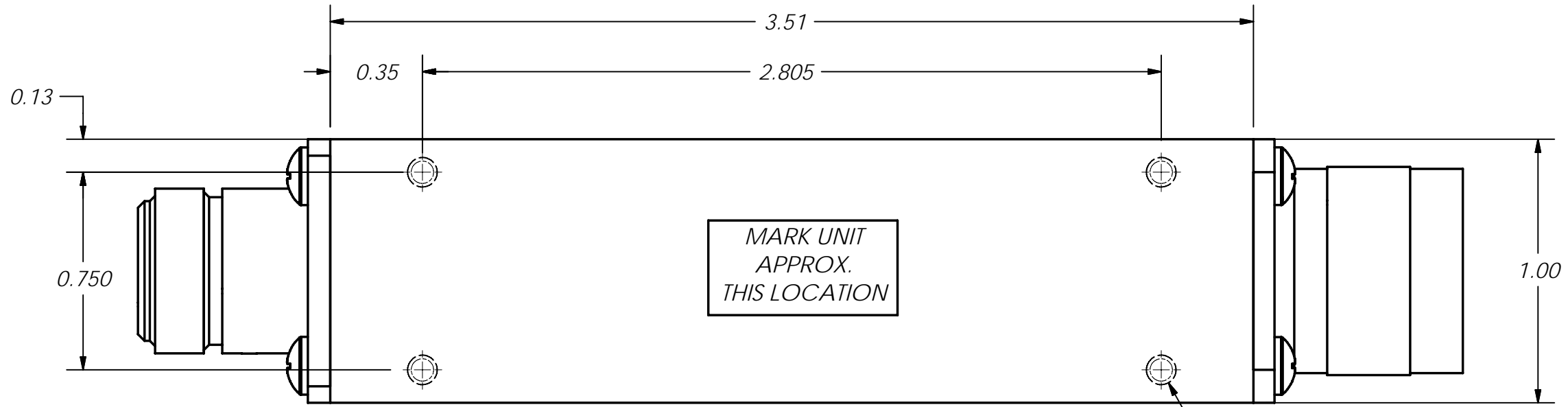
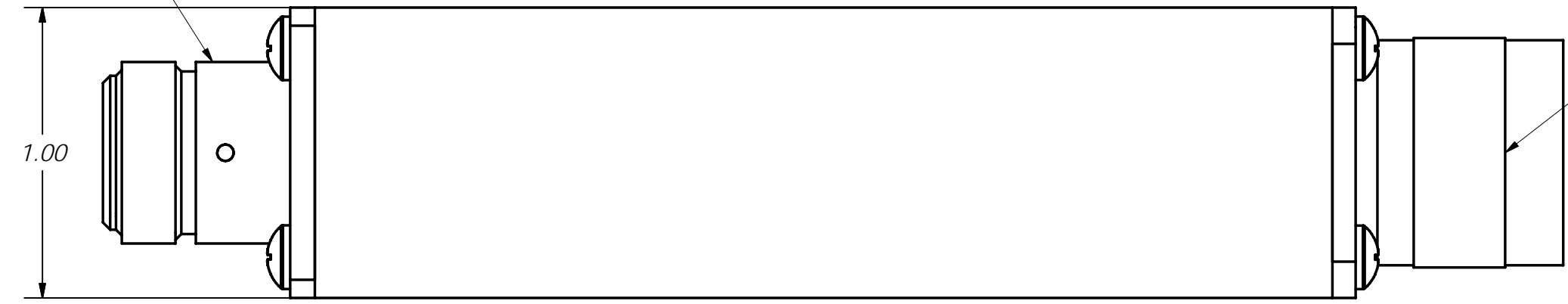

TYPE "N" MALE

2. MARKING: USING LABEL OR BLACK WORNOW INK TO INCLUDE:  
DELTA MICROWAVE, MODEL NO., SERIAL NO.,  
CODE IDENT. NO. 51719 AND DATE CODE

1: FINISH: HAZE GRAY EPOXY POLYAMIDE TOPCOAT  
PER MIL-DTL-24441C, SUP.1  
MIL-DTL-24441/21, TYP 3, FORMULA 151  
USING GREEN EPOXY POLYAMIDE PRIMER  
MIL-DTL-24441/20, TYP 3, FORMULA 150

NOTES:

UNLESS OTHERWISE SPECIFIED DIMENSIONS ARE IN INCHES TOLERANCES ARE:			CONTRACT NO. <i>U3917</i>	
FRACTIONS	DECIMALS	ANGLES	APPROVALS	DATE
+	.xx ± .03	+	DRAWN	01/05/06
-	.xxx ± .010	-	J.A. DE HORTA	
MATERIAL			REVISED	
FINISH			CHECKED	
USED ON MODEL#			APPROVED	
DO NOT SCALE DRAWING				



**Delta Microwave Inc.**

1301 VANGUARD DRIVE OXNARD, CA 93033

TITLE

*S3917 OUTLINE*

SIZE	CODE IDENT NO.	DWG NO
<b>B</b>	<b>51719</b>	<i>S3917</i>

SCALE 2:1 SHEET 1 OF 1