

THIS DOCUMENT CONTAINS INFORMATION PROPRIETARY TO DELTA MICROWAVE. ANY REPRODUCTION OF THIS DOCUMENT WITHOUT WRITTEN PERMISSION IS EXPRESSLY PROHIBITED.

| REVISIONS |     |                                     |          |          |
|-----------|-----|-------------------------------------|----------|----------|
| ZONE      | REV | DESCRIPTION                         | DATE     | APPROVED |
|           | A   | RELEASED                            | 09/22/99 |          |
|           | B   | CHANGE MARKING PER CUSTOMER REQUEST | 09/23/99 |          |

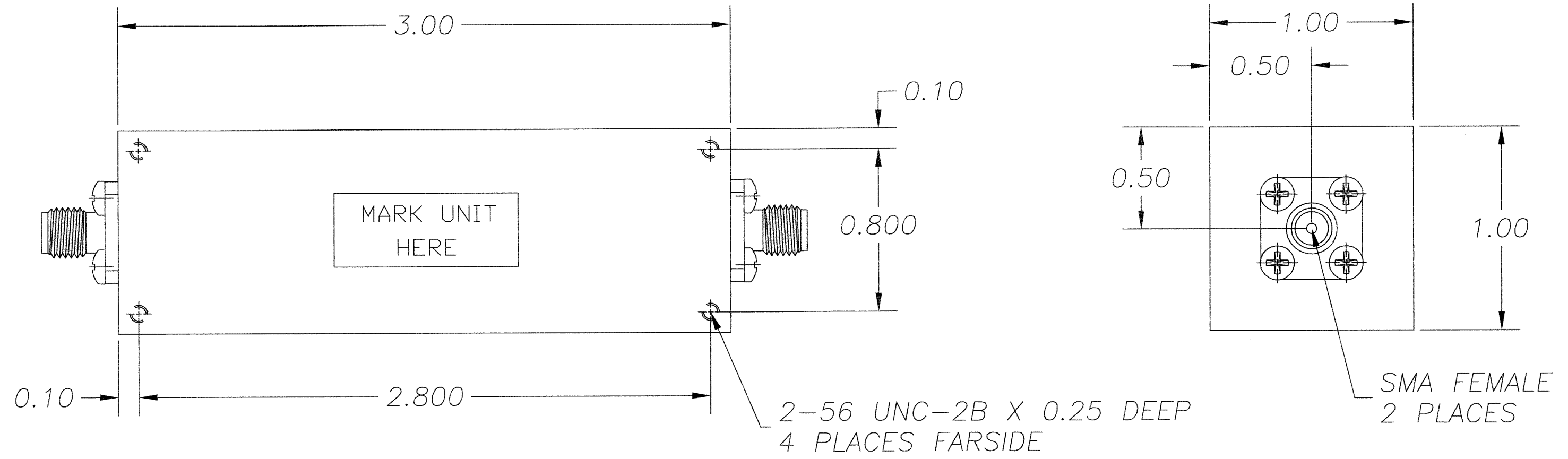

2-56 UNC-2B X 0.25 DEEP  
4 PLACES FAR SIDE

SMA FEMALE  
2 PLACES

2. MARKING: USING BLACK WARNOW INK TO INCLUDE:  
DELTA MICROWAVE, LOWPASS FILTER 300 MHZ., SERIAL NO.,  
CODE IDENT. NO. 51719 AND DATE CODE

1: FINISH: HAZE GRAY EPOXY POLYAMIDE TOPCOAT  
PER MIL-P-24441B TYP.1  
(AS) COLOR NO. 26270, FORMULA 151  
PER MIL-P-24441/1C, QPL 24441-103  
USING EPOXY POLYAMIDE PRIMER  
PER MIL-P-24441B TYP.1 24272 GREEN  
FORMULA 150 PER MIL-P-24441/1C, QPL 24441-103

NOTES:

| QTY REQD  | CODE IDENT | PART OR IDENTIFYING NO. | NOMENCLATURE OR DESCRIPTION                                     | MATERIAL SPECIFICATION |
|---|------------|-------------------------|---|------------------------|
| PARTS LIST  |            |                         |   |                        |
| UNLESS OTHERWISE SPECIFIED DIMENSIONS ARE IN INCHES<br>TOLERANCES ARE:<br>FRACTIONS DECIMALS ANGLES<br>+ .xx ±.01 +<br>- .xxx ±.005 - |            | CONTRACT NO.<br>U3930   | DELTA MICROWAVE<br>1301 VANGUARD DR.<br>OXNARD CALIFORNIA 93033 |                        |
| MATERIAL  |            | APPROVALS               | DATE  | TITLE                  |
| FINISH  |            | DRAWN<br>D.F. ESTABROOK | 09/22/99  | OUTLINE                |
| USED ON MODEL#  |            | CHECKED<br>             | 9/23/99   |                        |
| U3930   |            | APPROVED<br>            | 09/23/99  | SIZE<br>B              |
| DO NOT SCALE DRAWING  |            | CODE IDENT NO.<br>51719 |   | DRAWING NO.<br>U3930   |
| SCALE 2/1   |            |                         | SHEET 1 OF 1  |                        |