

THIS DOCUMENT CONTAINS INFORMATION PROPRIETARY TO DELTA MICROWAVE. ANY REPRODUCTION OF THIS DOCUMENT WITHOUT WRITTEN PERMISSION IS EXPRESSLY PROHIBITED.

REVISIONS				
ZONE	REV	DESCRIPTION	DATE	APPROVED
	A	RELEASED	06/02/98	<i>[Signature]</i>
	B	ADDED DC BIAS	06/25/98	<i>[Signature]</i>

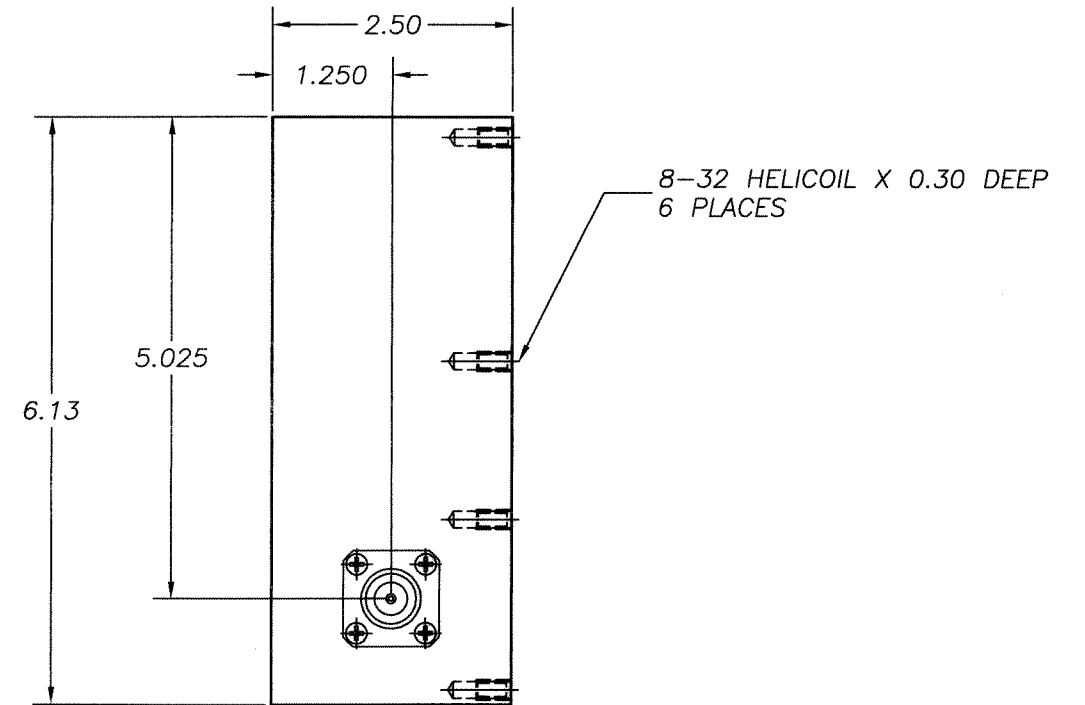
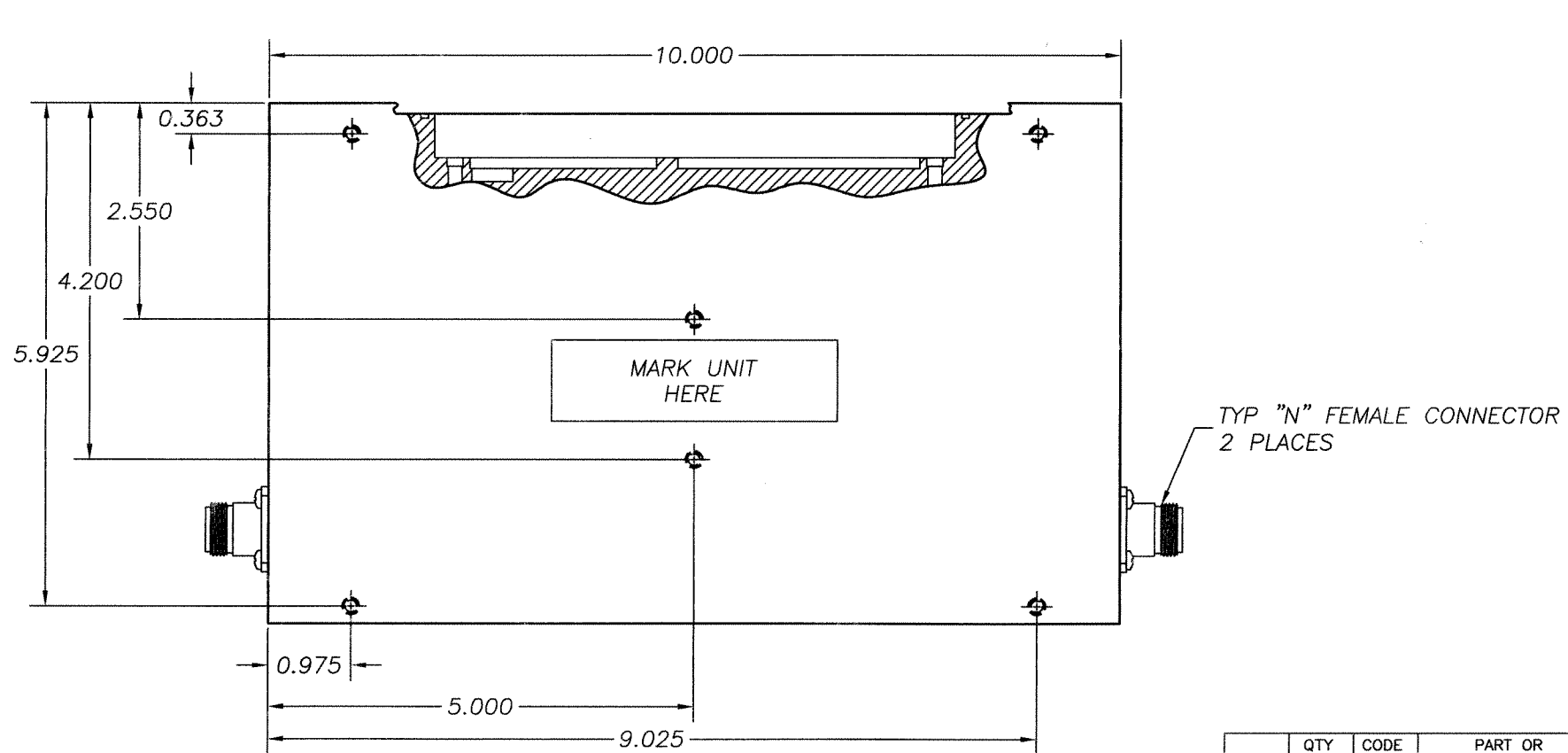
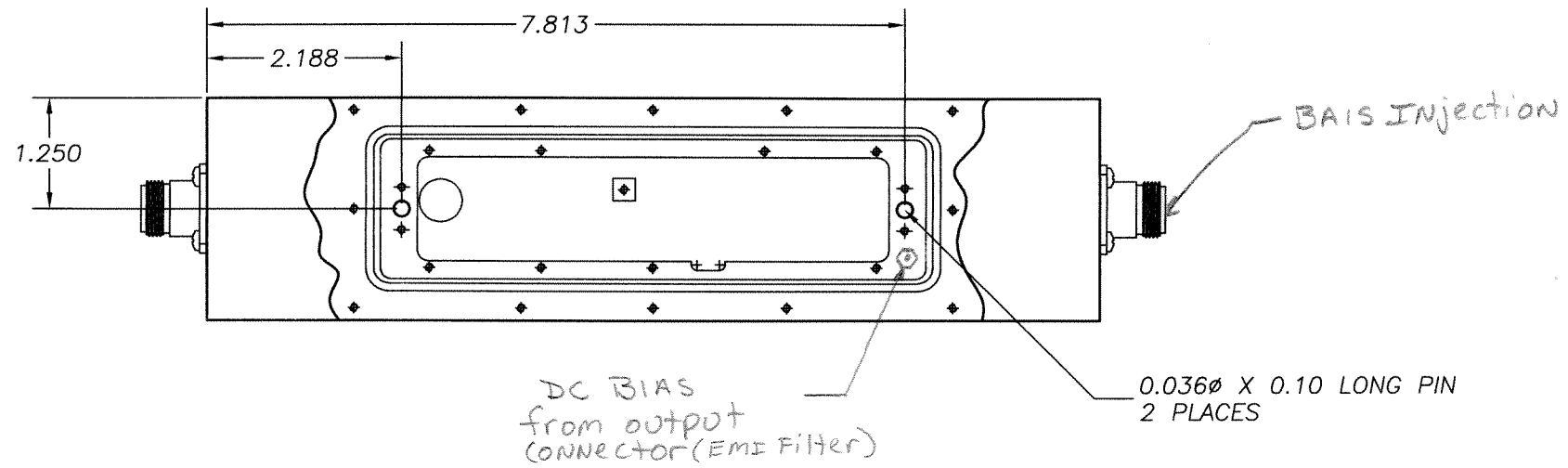

2. MARKING: USING BLACK WARNOW INK TO INCLUDE:
DELTA MICROWAVE, MODEL NO., SERIAL NO.,
CODE IDENT. NO. 51719 AND DATE CODE

1: FINISH: HAZE GRAY EPOXY POLYAMIDE TOPCOAT
PER MIL-P-24441B TYP.1
(AS) COLOR NO.26270, FORMULA 151
PER MIL-P-24441/1C, QPL 24441-103
USING EPOXY POLYAMIDE PRIMER
PER MIL-P-24441B TYP.1 24272 GREEN
FORMULA 150 PER MIL-P-24441/1C, QPL 24441-103

NOTES:

QTY REQD	CODE IDENT	PART OR IDENTIFYING NO.	NOMENCLATURE OR DESCRIPTION	MATERIAL SPECIFICATION
PARTS LIST				
UNLESS OTHERWISE SPECIFIED DIMENSIONS ARE IN INCHES TOLERANCES ARE: FRACTIONS DECIMALS ANGLES + .XX ±.03 + - .XXX ±.010 -		CONTRACT NO. U5634	DELTA microwave DELTA MICROWAVE 1301 VANGUARD DR. OXNARD CALIFORNIA 93033	
APPROVALS		DATE	TITLE OUTLINE	
DRAWN D.F. ESTABROOK		06/02/98		
MATERIAL		CHECKED DEB	SIZE B	
FINISH		APPROVED <i>[Signature]</i>		
DO NOT SCALE DRAWING		DATE 6/2/98	CODE IDENT NO. 51719	DRAWING NO. U5634
			SCALE 1/2	SHEET 1 OF 1