

THIS DOCUMENT CONTAINS INFORMATION PROPRIETARY TO DELTA MICROWAVE. ANY REPRODUCTION OF THIS DOCUMENT WITHOUT WRIT- TEN PERMISSION IS EXPRESSLY PROHIBITED.

REVISIONS				
ZONE	REV	DESCRIPTION	DATE	APPROVED
	A	RELEASED	02/04/00	R.E.S.
	B	ECO#106016	07/11/02	<i>[Signature]</i>

SMA FEMALE CONNECTOR
FIELD REPLACEABLE
2 PLACES

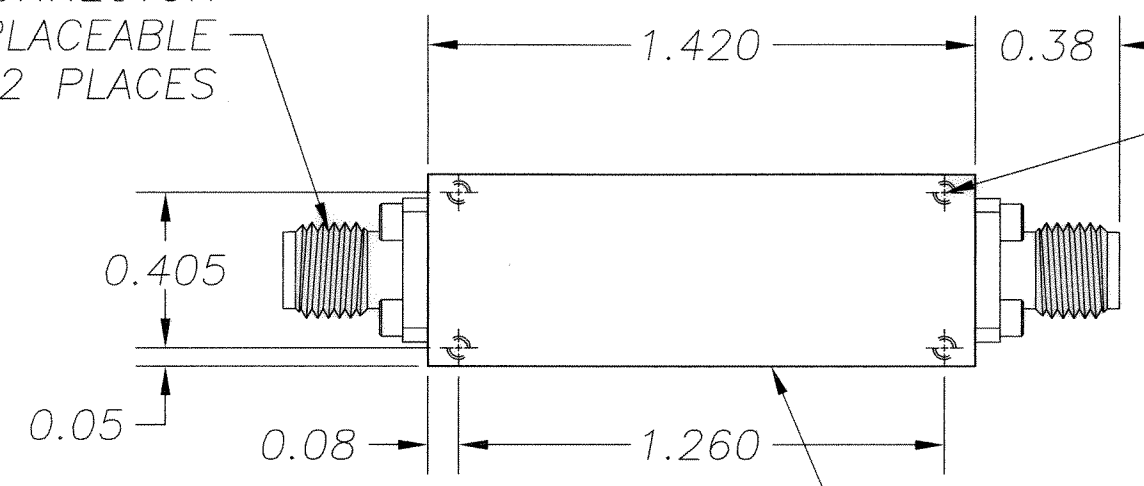

0-80 X 0.15 DEEP
4 PLACES FAR SIDE

0-80 TAP X 0.15 DEEP
8 PLACES FOR REMOVEABLE
0.375 SQ. FLANGE CONNECTOR

MARK THIS SURFACE

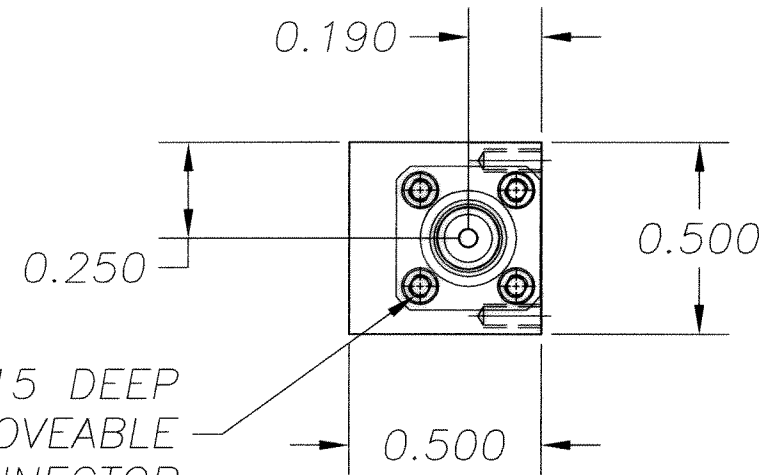

2. MARKING: USING LABEL OR BLACK WARNOW INK TO INCLUDE:
DELTA MICROWAVE, MODEL NO., SERIAL NO.,
CODE IDENT. NO. 51719 AND DATE CODE

1: FINISH: HAZE GRAY EPOXY POLYAMIDE TOPCOAT
PER MIL-P-24441B TYP.1
(AS)COLOR NO.26270, FORMULA 151
PER MIL-P-24441/1C, QPL 24441-103
USING EPOXY POLYAMIDE PRIMER
PER MIL-P-24441B TYP.1 24272 GREEN
FORMULA 150 PER MIL-P-24441/1C, QPL 24441-103

NOTES:

QTY REQD	CODE IDENT	PART OR IDENTIFYING NO.	NOMENCLATURE OR DESCRIPTION	MATERIAL SPECIFICATION	
PARTS LIST					
UNLESS OTHERWISE SPECIFIED DIMENSIONS ARE IN INCHES TOLERANCES ARE: FRACTIONS DECIMALS ANGLES + .XX ±.01 + - .XXX ±.005 -		CONTRACT NO. X1325	APPROVALS	DATE	DELTA microwave DELTA MICROWAVE 1301 VANGUARD DR. OXNARD CALIFORNIA 93033
MATERIAL		DRAWN D.F. ESTABROOK	CHECKED <i>[Signature]</i> 7/11/02	TITLE OUTLINE	
FINISH		APPROVED <i>[Signature]</i> 7/11/02	SIZE B	CODE IDENT NO. 51719	DRAWING NO. X1325
X1325		SCALE 2/1		SHEET 1 OF 1	
USED ON MODEL#		DO NOT SCALE DRAWING			