

THIS DOCUMENT CONTAINS INFORMATION PROPRIETARY TO DELTA MICROWAVE. ANY REPRODUCTION OF THIS DOCUMENT WITHOUT WRITTEN PERMISSION IS EXPRESSLY PROHIBITED.

REVISIONS				
ZONE	REV	DESCRIPTION	DATE	APPROVED
	A	RELEASED	02/02/00	R.E.S.
	B	ECO#104897	03/22/00	R.E.S.
	C	ECO#104905	04/13/00	R.E.S.
	D	ECO#104994	07/21/00	R.E.S.
	E	ECO#105009	08/01/00	R.E.S.
	F	ECO#105034	08/24/00	R.E.S.
	G	ECO#105074	10/02/00	R.E.S.
	H	ECO#105995	06/24/02	R.E.S.
	J	ECO#106648	02/14/05	<i>RB</i>

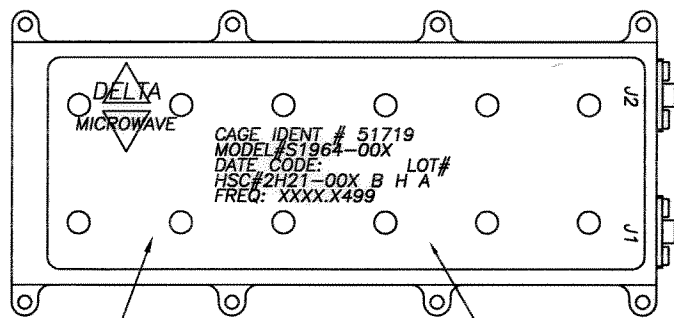

LABEL PER 105119

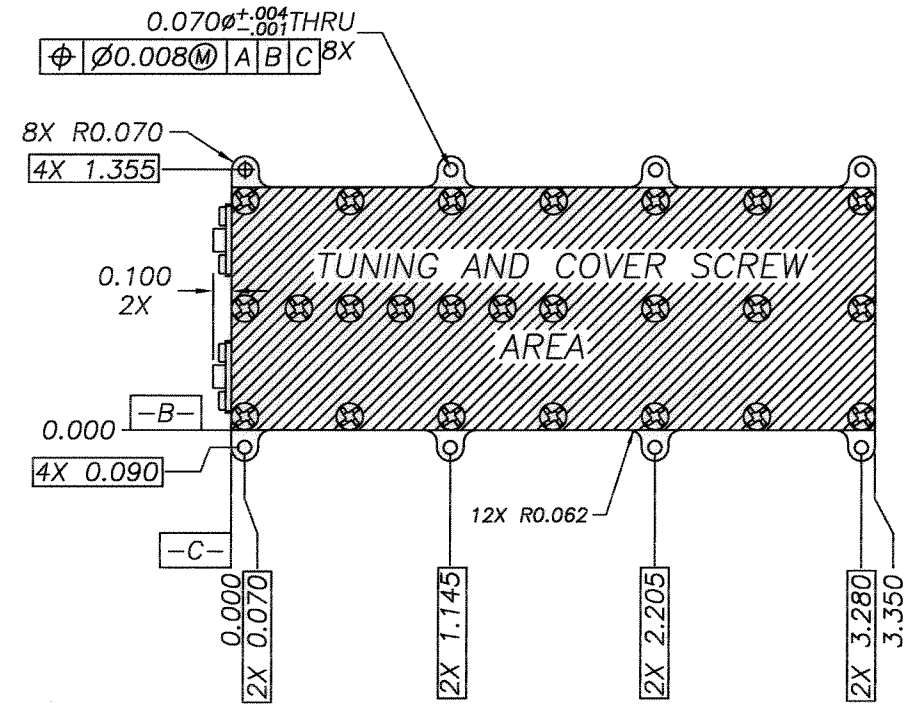
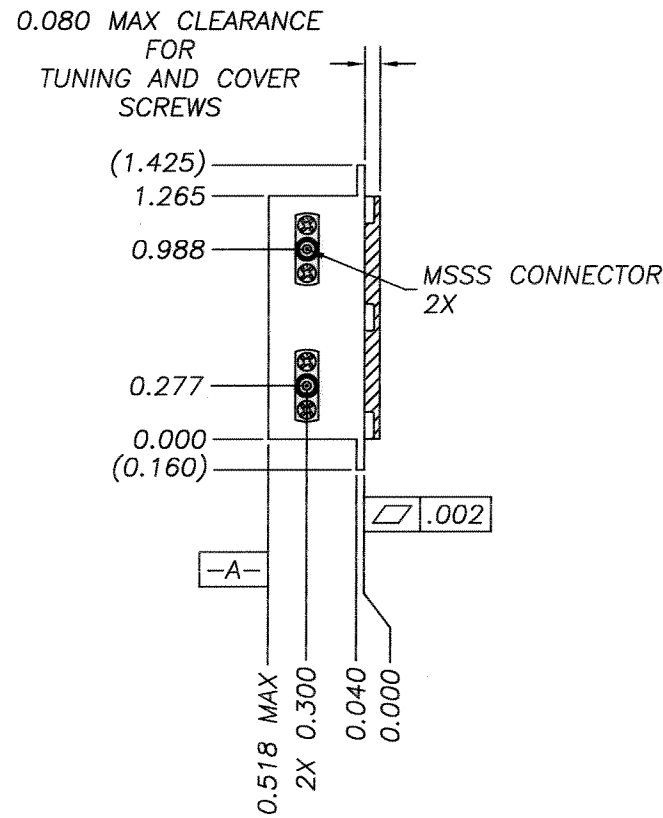

2. LABEL MUST COVER ALL OPENINGS

1: FINISH: SILVER PLATE PER QQ-S-365 TYPE 2 GRADE B

NOTES:

QTY REQD	CODE IDENT	PART OR IDENTIFYING NO.	NOMENCLATURE OR DESCRIPTION	MATERIAL SPECIFICATION
PARTS LIST				
UNLESS OTHERWISE SPECIFIED DIMENSIONS ARE IN INCHES TOLERANCES ARE: FRACTIONS DECIMALS ANGLES + .XX ± .03 + - .XXX ± .010 -		CONTRACT NO. S1964	DELTA microwave 1301 VANGUARD DR. OXNARD CALIFORNIA 93033	
		APPROVALS DRAWN D.R.BOWLER	DATE 02/02/00	TITLE OUTLINE
		CHECKED <i>S.A. Delatorre</i>	DATE 02/14/05	
		APPROVED <i>DRB RB</i>	DATE 2/14/05	
MATERIAL		FINISH	SIZE B	CODE IDENT NO. 51719
DO NOT SCALE DRAWING			DRAWING NO. S1964	
			SCALE 1/1	SHEET 1 OF 1